

► Introduction

1.Application

F8.11 electromagnetic flow meter, composed of sensor and converter, works based on Faraday's law of electromagnetic induction. It is used to measure electrical conductivity of liquid or solid. Generally, the electrical conductivity should be over 5uS/cm (electrical conductivity of tap water, raw water is about 100~500uS/cm),It can also be used to measure various mediums like acid, alkali, saline solution, paper pulp, ore pulp and so on. But these mediums can't contain a lot of magnetic materials and bubbles.

F8.11 electromagnetic flow meter is, a kind of instrument, used for measuring the flow conductivity liquid. It is widely used in flow measuring of Metallurgy, Chemical industry, Paper industry, Environmental protection, Oil industry, Textile industry, Food industry and City administration, Water works, etc.

2.Working Principle

The Principle of the sensor is based on Faraday's law of electromagnetic induction. It is installed a pair of detection electrodes on the pipe wall, where the measurement pipe axis and magnetic field lines are vertical. When the conductive liquid moves along the measurement pipe axis, the conductive liquid cuts magnetic field lines and produces induced electromagnetic force, which can be measured by the two electrodes on the meter pipe. The result can be calculated by formula:

$$E=KBVD$$

E-Induced electromotive force

K-Meter constant

B-Magnetic flux density

V-Average velocity of pipe section

D-Internal diameter of measuring pipe

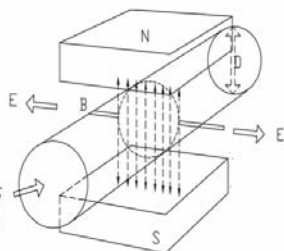

When measuring flows through magnetic field which is perpendicular to the direction of the flow. Then the flow of conductive fluid induces electromotive force proportional to the average velocity. Therefore, the detected fluid requires to be higher than the minimum of electrical conductivity. Its induced voltage signal is detected through two electrodes and sent to a converter through the cable. After signal processing and related operation, the electromagnetic flow meter will display total flow and instantaneous flow in monitor.

3.Instrument characteristics

- 1). No baffles and running part inside the measuring tube, therefore no additional flow loss and no jams happen. Especially for measuring the flow of solid-liquid object, for example, sewage, mud pulp and CWS (coal water slurry).
- 2). Only liner and electrode have direct contact with the measuring medium, by choosing correct liner and electrode, then the corrosion resistance and wear resistance can be satisfied. Therefore it can be used in kinds of strong acid and alkali in chemical solutions.
- 3). Easy for installation, 5D for front straight pipe, 2D for back straight pipe(D means inner diameter of chosen instrument).
- 4).High accuracy, it is up to $\pm 0.2\%$, it is capable for testing forward/reverse Bi-directional flow.

- 5). Dual frequency excitation is adopted to avoid the affection from public frequency.
- 6). Low consumption.
- 7). Good interchangeability of the converter, it is easy to have the accuracy without remark the real flow.
- 8). Wide ranges.
- 9). Empty pipe diagnosis automatically. When the pipe is empty, the system will set the number to zero and alarm, to prevent interference from empty pipe which will make the instruments data bounce and misuse.
- 10).Both cone and line seal method are used in sealing the electrodes to make sure there is no leaks.
- 11). The input impedance of the converter is more than 1012ohms,it protects the sensor from fouling, it is good for measuring the low conductivity medium.
- 12). EMC of flow meter comply with IEC61000-1995 standard.

Due to the advantages of electromagnetic flow meter, it is widely used in various industries, and the preferred instrument for liquid flow measuring.

- 13).With Automatic Electrodes Cleaning.

4.Feature



- 1).“Fuzzy Algorithm” technology is applied on the measurement of electromagnetic flow meter and equipped with the artificial intelligence function.
- 2).An EEPROM retains data record for approximately 10 years.
- 3).Explosion-proof design upon request.
- 4).High resistance, fast response design can make undistorted collection of weak signal and fast response to the flow changes. Its range rate can reach 100:1.
- 5). It has the function of low conductivity measurement.
- 6).Capacitance technology is applied on full and empty pipetesting to avoid wrong alarms.
- 7).It has the consistency of converter's interchange, which can avoid input parameters repeatedly.
- 8).Variety of power supply mode is available (DC: 18V-36V/AC: 85V-265V).
- 9).The function of saving settings before delivery, which can avoid the loss of the parameters.
- 10).It adopts the international leading excitation technology, which circuit is simple, stable, and reliable.
- 11).It has the function of infrared remote control and button operation so as to make the operation more convenient.
- 12).It provides the function of zero correction of sensor and automatic zero adjustment.
- 13).Multi-language interface to satisfy all the users' need.
- 14).It has the function of self-adjustment and self-checking.
- 15).It has lightning-protection and electricity-protection circuits. The effective, anti-interference circuits apply to all kinds of bad environment.
- 16).The instrument provides current flow rate and flow totalization indication with back light LCD display.
- 17).Flow Rate Cut-off (Hi/Low) can be programmable.
- 18).HART communication function and other output communication interfaces are available (optional).

5. Electromagnetic flow meter for measuring Heat (Energy)

F8.11 electromagnetic flow meter also have a function for measuring heat (energy) (Please inform us when you place orders), it is a kind of metering instrument for measuring the heat(energy) from heat-conducting fluid which belong to the heat exchange system. Through carrying high accuracy and stable Platinum resistance (PT1000) as measuring elements, to make the heat(energy)meter has a very excellent



► Main Technical parameters

F8.11 Electro magnetic flow meter								
	Divided type		Integrated type(IP67)		Explosion-proof Integrated		Battery powered type	
Accuracy	±0.2% or ±0.5%							
Diameter	DN10~DN2400			DN10~DN600			DN25~DN1400	
Flange	Comply with GB9119 Standard carbon steel (stainless steel us optional)							
Pressure	DN10~DN600 1.0、1.6、2.5、4.0MPa DN700~DN2400 0.6、1.0、1.6MPa			DN10~DN600 1.0、1.6、2.5、4.0MPa			DN25~DN600 1.0、 1.6、2.5、4.0MPa DN700~DN2400 0.6、 1.0、1.6MPa	
	Please consult us if you need special pressure							
Liner	PTFE.PU.CR.PFA.F46.HARD RUBBER							
Conductivity	≥5μS/cm (Please consult us if you need special pressure)							
Electrode	316L,Hastelloy,Ti,Ta,PT-It							
Protection level	IP67(For sensor,IP68 is optional)	IP67	IP67	IP68	(Type of temperature sensor:PT1000) IP67 IP68			
Medium Temperature	-25℃~180℃ (Please refer to liner material)	-25℃~80℃ (Please refer to liner material)			-25℃~180℃ (Please refer to liner material)			
Influence of Ambient temperature	-25℃~60℃ <±0.1%/10℃ or <±0.25%/10℃							
Repetition	≤±0.1%、±0.25%							
Analog output Error	≤±0.02mA							
Velocity	≤20m/s							
Electrical connection	M20×1.5seal、G1/2、NPT1/2							
Output interface	Standard output(4~20mA)、Dual current output. RS485,HART,Profibus-PA							

► **Size**

1.Dimension of converter

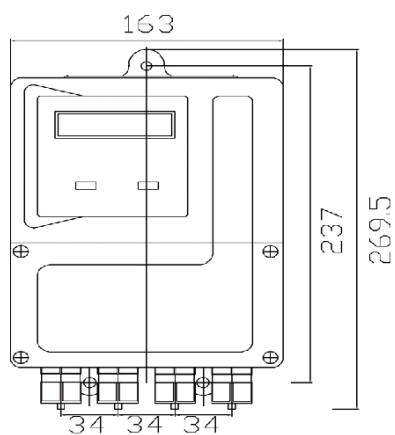

Divided type

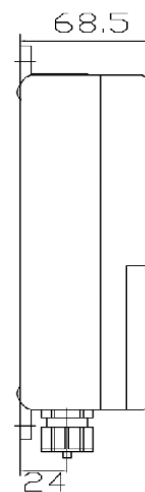

Divided type

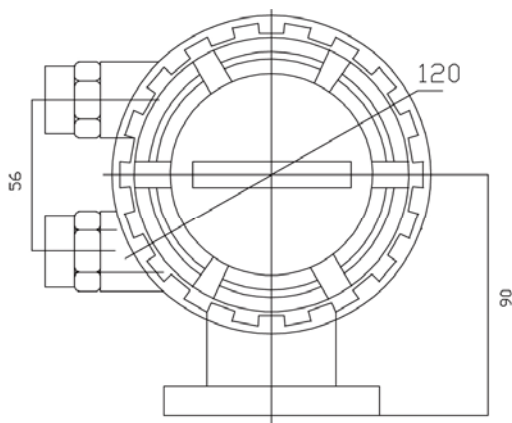

Compact type

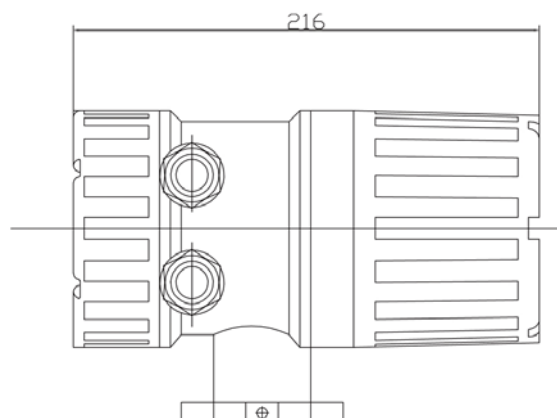

Compact type

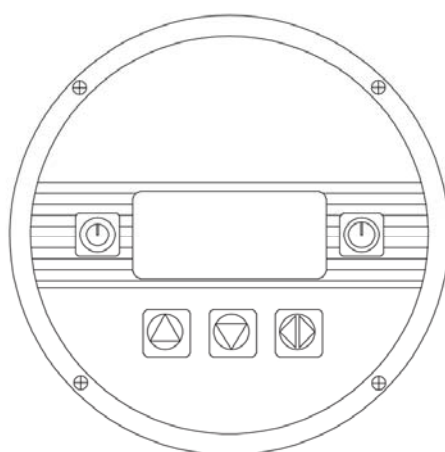

Battery Powered

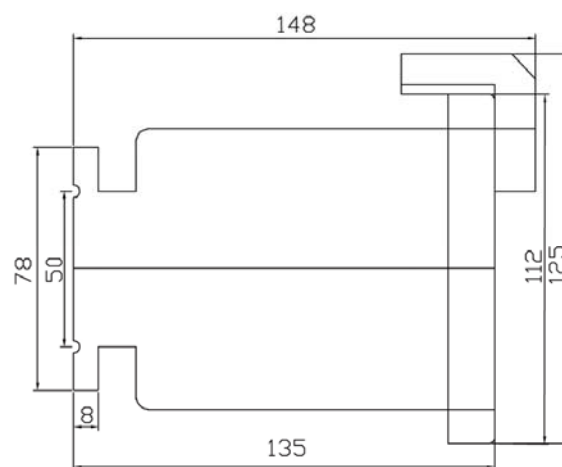

Battery Powered

2.Dimension of the sensor

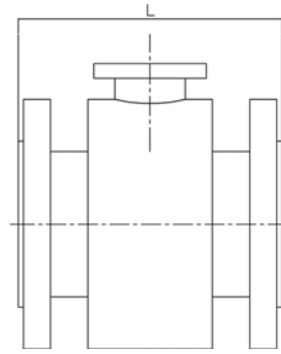
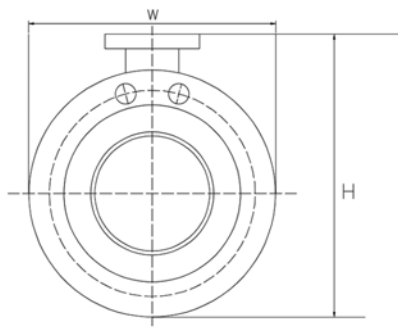

Diameter(mm)	Size(mm)	
	L	H
15	160	175
20	160	180
25	160	186
32	160	200
40	200	210
50	200	225
65	200	240
80	200	255
100	250	275
125	250	300
150	300	335
200	350	390
250	400	450
300	500	505
350	500	556
400	600	615
450	600	670
500	600	725
600	600	845
700	700	930
800	800	1035
900	900	1135
1000	1000	1250
1200	1200	1465

Custom-made also available (Upon request)

(For reference only)

► Selection of lining material

Lining materials should be chosen according to the erosion, abrasion and temperature of measured medium, Neoprene is resistant to general weak acid and alkali corrosion and to 80°C. PTFE has a good resistance to corrosion of strong acid and alkali except Hot phosphoric acid. The temperature of the medium could reach 180°C but with poor abrasion. PU has a good abrasion but has a poor resistance to the corrosion of acid, alkali and high temperature, the temperature should be below 65°C.

The performance and usable range of common lining materials(Only for reference)

Lining material	Main Performance	Applied Scope
PTEE	1. Have the most stable chemical properties in plastics, and resist boiling hydrochloric acid and sulfuric acid, nitric acid aqua regia, strong alkali, and all kinds of organic solvents, but can not resist the corrosion of chlorine trifluoride, high temperature nitrogen trifluoride, liquid fluorine, liquid oxygen and ozone. 2. Low abrasion resistance. 3. Low negative pressure resistance	1. -25~140°C 2. Strong corrosion medium, like strong acid and alkali. 3. Healthcare medium.
CR	Oil proof, solvent resistance, oxidant resistance and the resist the erosion of common medium like acid, alkali, salt, etc	1. <80°C 2. be able to measure sewage and mud.
PU	1. Very good abrasive resistance, flexibility. 2. Low acid and alkali resistance.	1. <65°C 2. Neutral strong abrasion resistance medium.
Hard Rubber	1. Good resistance to room temperature, hydrochloric acid, acetic acid, oxalic acid, ammonia, phosphoric acid and 50% sulfuric acid, sodium hydroxide, potassium hydroxide 2. Avoid strong oxidants	1. <80°C 2. General acid, alkali, salt solution
PFA	1. Can be used for most corrosive medium like acids, alkalis, and strong oxidant. 2. High material strength, resistance to aging, better than PTFE, EFP In high temperature 3. Injection molding for higher negative pressure	1. 40-180°C 2. Strong corrosion medium, like strong acid and alkali. 3. Healthcare medium.
FEP(F46)	1. Hydrophobicity and non-viscous. 2. Corrosion resistance is inferior to PFA 3. Negative pressure	1. 40-180°C 2. Strong corrosion medium, like strong acid and alkali. 3. Healthcare medium.

► Selection of Electrode materials

The choice of electrode material should be confirmed by the corrosion resistance of the measured medium.

The corrosion resistance of the electrode material (Only for reference, detailed in appendix)

Electrode material	Main Performance
316L	Good resistance to the corrosion of nitric acid, <5% Sulfuric acid under room temperature, Acetic acid, Alkaline fluid, Sulfite under certain pressure, seawater and Acetic acid, etc. It can be widely used in the petrochemical, urea, vinylon
HB	Good resistance to the all the concentration of hydrochloric acid below the boiling point, also resist the corrosion of non-oxidizing acid, alkali, salt like sulfuric acid phosphoric acid hydrofluoric acid, organic acids.
HC	Resist the corrosion of oxidizing acids like metric acid, mixed acid. the mixture of chromium acid and sulfuric acid, and salts of oxidative, like Fe ⁺⁺⁺ , Q ⁺⁺⁺ , and some other oxidants, like hypochlorite salt solution higher than normal temperature and seawater.
Ti	Resist the corrosion of seawater, various chlorides, hypochlorite, oxidizing acid (including fuming nitric acid), and organic acid or alkali, but don't resist the corrosion of pure reducing acid (like sulfuric acid, hydrochloric acid). But if acid includes oxidants (like nitric acid, Fe ⁺⁺⁺ , Q ⁺⁺⁺), the corrosion resistance will decrease.
Ta	Good corrosion resistance similar to glass. Resist the corrosion of chemical medium (including hydrochloric acid and fuming sulfuric acid), but can not be used for Sodium hydroxide fluid.
Pt-Ir	Have good corrosion resistance of all acid, and can resist the corrosion of alkali, all salt except Aqua regia, ammonium salt and few other medium.
Tungsten Carbide	For pulp and sewage, good resistance to solid particle interference.

► Selection of Protection Level

According to the GB4208-84 IEC standard (IEC529- 76) on the protection level:

IP65 means water-jet type; it allows the taps spray from all the directions of the instrument. the pressure is 30kPa(0.3bar),the output of the water is 12.5l/m,and the taps is 3 meters far from the instruments.IP67 means anti-immersion type, it can be submerged in the water in a short time, when testing, the highest point in the experiment should be at least 15cm underwater and last for at least 30 minutes.

IP68 means Submersible-type, it can work in the water for long-term, Its maximum depth in the water should be consulted by the manufacturer and the user.

The choice of protection should be selected in accordance with the above requirements, as well as the actual instrument conditions. If the meter works under the ground and always submerged by the water, IP68 should be selected, If the instrument is installed above ground, IP65 is optional.

► Selection of Ground Ring

If the pipe connecting to the meter is insulated, the ground ring is needed, generally metallic or non-metallic grounding rings or grounding electrode (non-metallic) material is available to adapt to the corrosion of the measured material.

If the measured medium is abrasive, ground ring with neck should be used to protect the lining material of two sides and to prolong its life.

In order to make the reliable operation of the instrument, and to improve measurement accuracy, free from outside interference of Send potential, the sensor should have separate ground wire, and the ground ring of both sides of the sensors should be fitted when the ground resistance, in the pipe connecting to the sensor or non-metallic pipe, is less than 10Ω.

1. The form of ground ring

A.The General metal or non-metallic ground ring

Material: Optional

Thickness: 3mm-12mm

The guard ring is used in the sensor with PTFE lining material, and fixed in the flange by the screws to protect the edge of the PTFE.

B.The ground ring with neck

Materials: Optional

Thickness:3mm

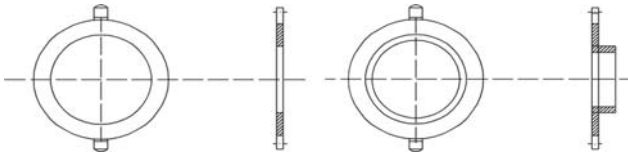

A.General or PVC grounding ring B.Ground ring with neck

The ground ring with neck is used for abrasive medium such as magma, CWS and so on. it is used to protect the lining in the bottom of the measuring pipe, to prolong its life. This ground ring should be ordered along with meter, otherwise the accuracy of the meter which did not have the ground ring set before would be affected

2.Ground Method

A.The installation of the sensor on the pipe: ground as the following figure as the inner wall of the pipe without Insulating coating.

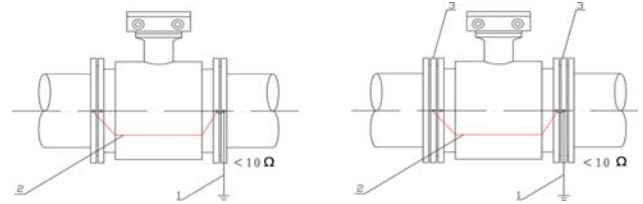

A:1.Earthing cable
(Install when outside interference)

2.Instrument ground wire
(Factory supplied)

B:1.Earthing cable
(Install when outside interference)

2.Instrument ground wire
(Factory supplied)
3. The ground flange or ground ring

B.The installation of the sensor on the pipe with isolating coating or printing exists on the inner wall: the ground ring should be installed in the surface of each side of the sensor, and make the measured medium occur short circuit with the ground, and zero potential was provided. if not, the magnetic flow meter can not work normally.

C.The Installation of the sensor on the cathodic-protection pipe: Between the cathodic-protection pipe and the ground exist a certain potential difference, the measured medium has a high common-mode ground potential, so the ground ring must be installed in the sensor.

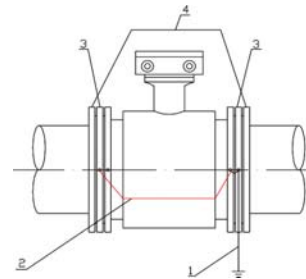

1.Earthing cable (install when outside interference);

2.Instrument ground wire (factory supplied);

3.The ground flange or ground ring must be insulated to the flange connecting to the pipe;

4.Connecting wires, copper cross-sectional area of 16mm², forming an isolation between the cathodic protection potential and sensor.

3.The installation of the sensor on the cathodic-protection pipe.

Warning:

1) the ground ring is amounted on the two surface of the sensor, it must be isolated from the flange connecting to the pipe, and make the sensor and ground ring connected through ground wire 2,the material of ground ring should be resistant to the corrosive medium, the standard material that the manufacturer provide is stainless steel ICr18Ni9Ti.

2) The flange on the both sides of instrument should be connected to the sensor by the cross-sectional area of 16mm copper wire to make the cathodic protection potential and sensor isolated. the cathodic protection pipeline and sensor are isolated.

to the both sides of the connecting duct. When installing, please note the following points:

The ground ring isolated to the flange of pipe must be installed on the both sides of the meter(and the grounding of low mete, and measuring ground must be connected to each other).

The pipe and flange must be connected with copper wire (L), and avoiding connecting to the sensor.

The flange bolts must be insulated (as pictured) the customer must use the liner and gasket made of isolated materials.

- 1.Sensor flange
- 2.Lining
- 3.Seals
- 4.Pipe flange
- E.Ground ring
- 5.Bolt
- 6.Nuts
- 7.Gasket
- 8.Insulating bush

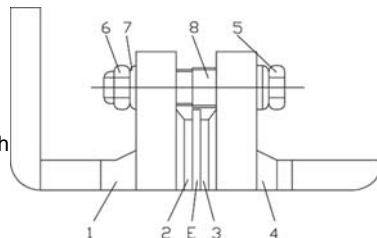

► Selection of the Sensor(Piped)

1.Option of the Instrument Diameter

1.1 Sensor diameter Selection

The diameter of the meter is not necessarily the same size as the diameter of pipe, it should be determined by the flow rate.

Generally, the flow rate between 0.1-10 m/s is called economic flow rate, and the diameter of sensor is the same size as the diameter of pipe. Unless the medium gets a less abrasion, and use the abrasion-resistant medium, otherwise we recommend it would not exceed 7m/s for long-term working.

For the flow contains material of adhering, precipitating and scaling, we recommend flow of 2m/s, preferably up to 3-4m/s or more to achieve self-cleaning and prevent adhering and scaling; For those strong abrasive fluid like slurry, the common flow should be less than 3m/s to reduce the abrasion to the lining and electrode; for the low conductive medium within 5-10 μ S, the flow of 0.5-1m/s would be better. Du to the increase of the flow rate will increase the flow noise, the output shake will appear.

1). Accuracy

Diameter(mm)	Boundaries flow rate(m/s)	Standard accuracy(A)	High accuracy	S
15-300	V \geq 0.3	$\pm 0.5\%$ RS	$\pm 0.2\%$ RS	Special calibration
	V<0.3	$\pm 1.5\text{mm/s}$	$\pm 0.6\text{mm/s}$	
350-600	V \geq 0.5	$\pm 0.5\%$ RS	$\pm 0.2\%$ RS	
	V<0.5	$\pm 2.5\text{mm/s}$	$\pm 1\text{mm/s}$	
700-1000	V \geq 0.5	$\pm 0.5\%$ RS	Special Instructions: DN700 special order accuracy up to $\pm 0.3\%$ (Flow rate \geq 1m/s or $\pm 3\text{mm/s}$)	
	V<0.5	$\pm 2.5\text{mm/s}$		
≥ 1200	V \geq 0.8	$\pm 0.5\%$ RS		
	V<0.8	$\pm 4\text{mm/s}$		

NOTING: Correction technology could be used to reduce the boundaries flow rate.

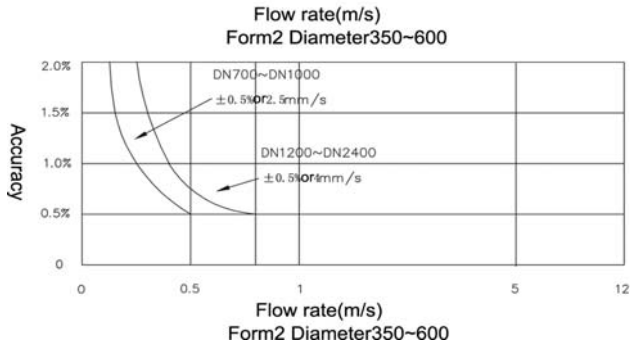
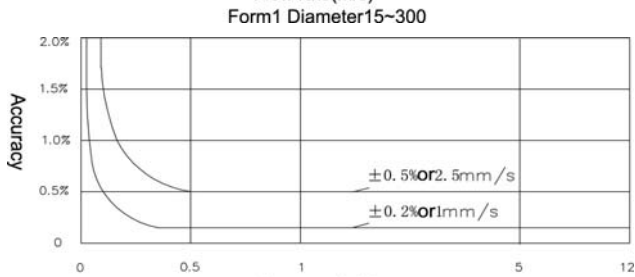
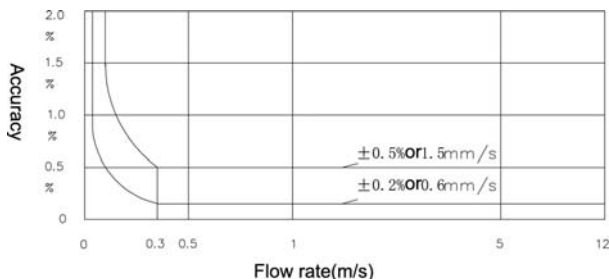

2).Selecting the diameter of instrument please refer to the following tables:

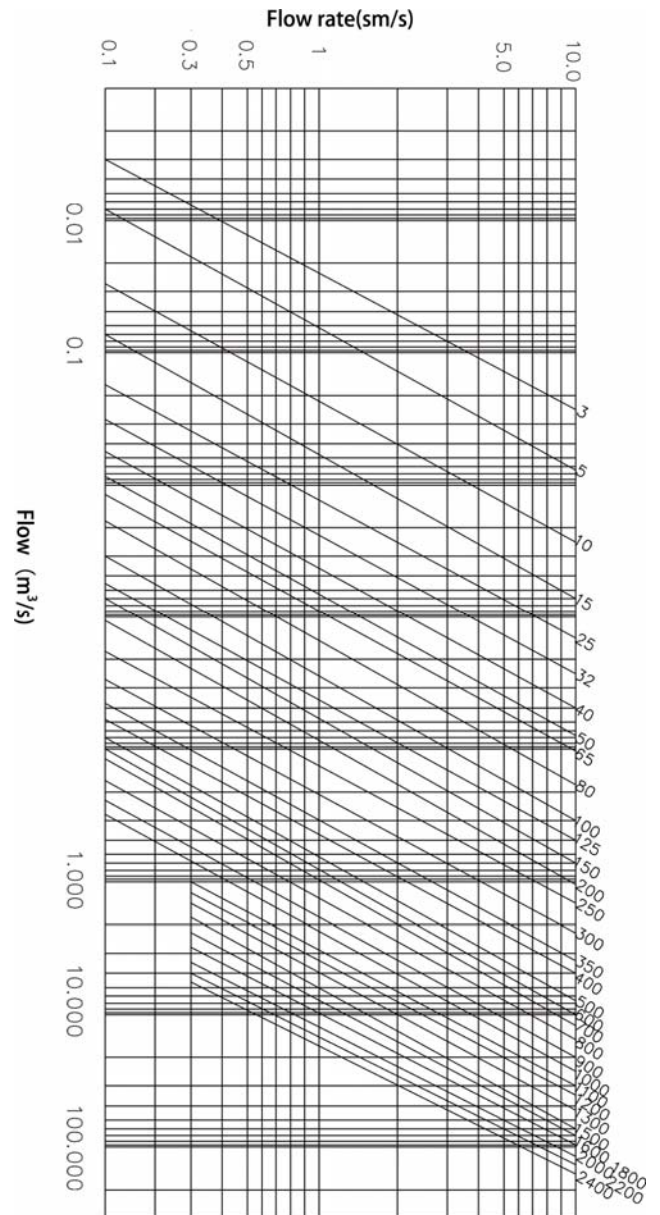

► F8.11 series magnetic flow meter selection table
Model Selection

Type of Instrument	F8.11	
Installation form	C	Flange, Compact Type
	D	Flange, Divided Type (5 m STD cables)
	I	Wafer, Compact Type
	S	Wafer, Divided Type (5 m STD cables)
Size	10~2400	10~2400mm
Electrode material	A	Stainless Steel 316L
	B	Hastelloy B
	C	Hastelloy C
	D	Titanium
	E	Tantalum
	F	Tungsten Carbide
	O	Others
Lining material	R	CR
	P	PTFE
	O	Others, Specify
Measuring pipe material	4	Stainless Steel 316
	6	Stainless Steel 304
Flange material	6	Stainless Steel 316
	4	Stainless Steel 304
	2	Carbon Steel Paint
Cover material	D	Stainless Steel 316
	E	Stainless Steel 304
	F	Carbon Steel Paint
Process Connection	1	JIS 10K
	2	JIS 20K
	3	ANSI 150#
	A	ANSI 300#
	B	PN 10
	C	PN 16
	D	PN 25
	E	PN 40
	O	Others, Specify
	Output Signal and Communication	S
R		Pulse& 4-20mA with RS485
H		Pulse& 4-20mA with Hart
O		Others, Specify
Power Supply	0	220/110 VAC, Specify
	1	24 VDC
	2	Battery type
Protection Level	0	IP65
	1	IP67
	2	IP68 (Divided Type only)
Accessory	N	None
	1	Grounding ring
	2	Matching flange
	3	Grounding ring& Matching flange
Option	N	None
	R	Heat with PT1000
	X	Explosion Proof
	H	High Temp:100~180°C
Accuracy	X	±0.5%
	S	±0.2%
Special Remark	X	Specify